

1000 Series

1006-6T

Diesel Engine –
ElectropaK

120.0 kWm 1800 rev/min

Renowned throughout the power generation industry for their superior performance and reliability, the latest Perkins 1000 Series easily satisfies the requirements of US EPA mobile off-highway legislation.

The 1006-6T is a turbocharged, 6 cylinder, 6 litre engine. Its premium design features provide economic and durable operation offering the ideal characteristics for electrical power generation.

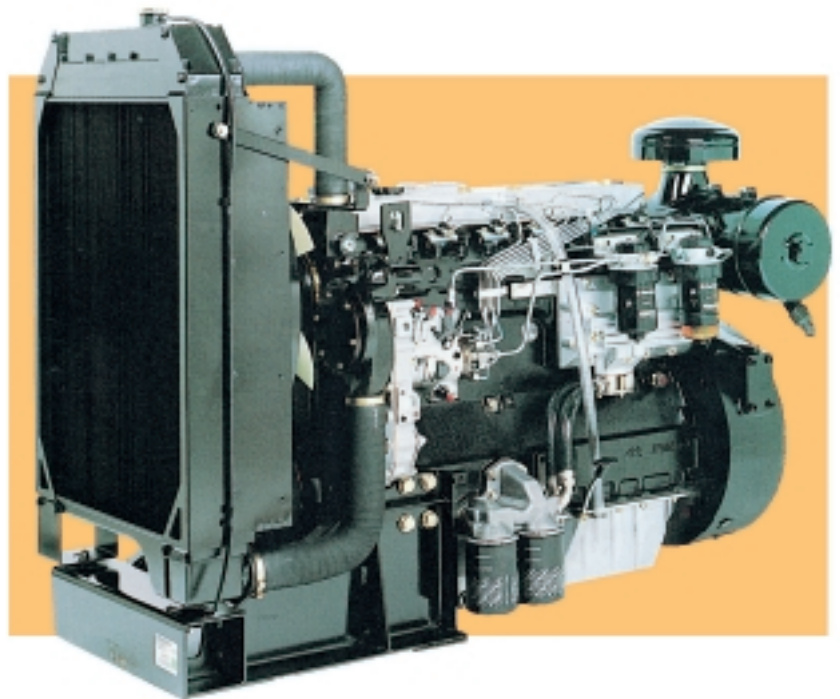

Clean, efficient power

- **Operator and environmentally sensitive** with low noise, rapid startability and low emissions satisfying US EPA mobile off-highway legislation.

Economic power

- **Single side servicing** reduces service time, cost and enhances equipment availability.
- **Perkins advanced combustion system** ensures high power with low specific fuel consumption and noise.

Durable power

- **Maximum cooling efficiency is provided by a high capacity gear driven water pump** and independent fan drive.
- **Leak free operation is ensured by Viton crankshaft seals** and sophisticated controlled swell joints, giving protection in the toughest conditions.
- **Inserted valve seats, oil spray cooled pistons and compact plate cooler** give enhanced engine life.

Reliable power

- **Suitable for operation** in ambient temperatures up to 53°C (46°C if a canopy is fitted).
- **Fuelled starting aid** for temperatures down to -30°C.
- **Wherever a Perkins' ElectropaK engine** is put into service, it will never be far from the support provided by a global network of 4000 distributors and dealers, all backed by a parts distribution centre giving 24 hour service, 365 days a year.

Engine Speed rev/min	Type of Operation	Typical Generator Output (Net)		Engine Power			
		kVA	kWe	Gross		Net	
				kWm	bhp	kWm	bhp
1800	Prime power	123.0	98.5	112.5	151.0	109.5	147.0
	Standby power	135.0	108.0	123.5	165.5	120.0	161.0

All ratings data based on operation under ISO 3046 conditions using typical fan sizes and drive ratios. For operation outside of these conditions please consult your Perkins Engines contact. Performance tolerance quoted by Perkins is ±5%.

Electrical ratings assume a power factor of 0.8 and a generator efficiency of 90%.

Rating Definitions

Prime power – Power available at variable load in lieu of main power network. An overload of 10% is permitted for one hour in every twelve hours of operation.

Standby power – Power available at variable load in the event of a main power network failure. No overload is permitted.

Standard ElectropaK Specification

- Base engine
- Cast iron SAE 3 flywheel housing
- Flywheel
- Flat bottomed aluminium sump
- Mechanical governor – speed control to BS5514 Class A1, ISO 3046-4M3
- Rotary fuel injection pump
- 12V shut off solenoid – energised to run
- Cold start aid
- Spin-on full flow fuel oil filter
- Fuel pre-filter
- Spin-on full flow oil filters
- Oil cooler
- Thermostat controlled cooling system
- Gear driven water pump
- Fan drive and 22" pusher fan
- Radiator (and piping)
- Fan guards
- Front engine mountings
- 12V engine alternator
- 12V starter motor
- Air filter
- Oil pressure switch
- Coolant temperature switch

Optional Equipment

- 24V alternator
- 24V starter motor
- Water temperature gauge and sender
- Heater/starter switch
- Rear engine mountings
- Workshop manual
- Parts book
- User handbook

ElectropaK General Data

Number of cylinders	6
Cylinder arrangement	Vertical, in-line
Cycle	4-stroke
Induction system	Turbocharged
Combustion system	Direct injection
Cooling system	Water-cooled
Displacement	5.99 litres
Bore and stroke	100.0 mm x 127.0 mm
Compression ratio	17.3:1
Direction of rotation	Clockwise, viewed from the front
Firing order	1,5,3,6,2,4
Total lubrication system capacity	16.1 litres
Coolant capacity (inc radiator)	27.7 litres
Total weight (dry)	586 kg
Total weight (wet)	623 kg

Fuel consumption litres/hour (UK gallons/hour)	
Power rating %	1800 rev/min
110	32.0 (7.0)
100	29.2 (6.4)
75	22.5 (5.0)
50	16.4 (3.6)

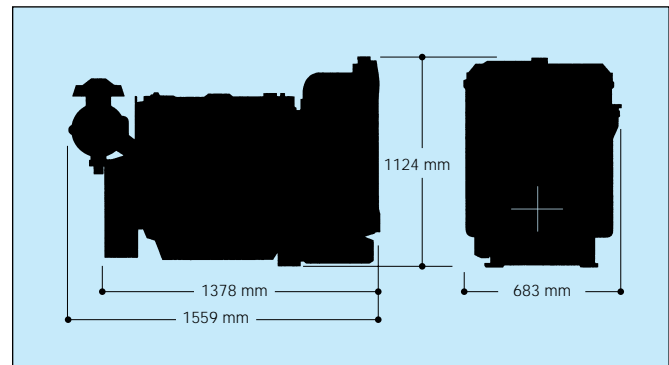

Perkins Engines Company Limited

Peterborough PE1 5NA UK
 Telephone +44 (0)1733 583000
 Fax +44 (0)1733 582240
www.perkins-engines.com

All information in this document is substantially correct at the time of printing but may be altered subsequently by the company.

Distributed by